

# ADIABATIC DUCT TYPE HUMIDIFIER HUMON H250

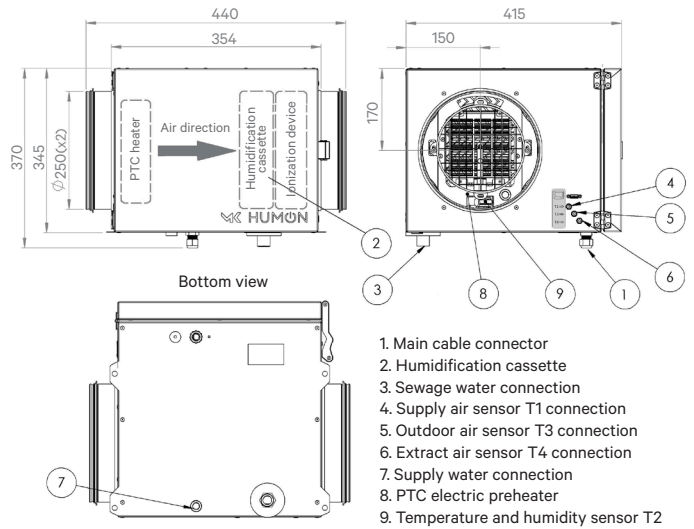

1. Main cable connector
2. Humidification cassette
3. Sewage water connection
4. Supply air sensor T1 connection
5. Outdoor air sensor T3 connection
6. Extract air sensor T4 connection
7. Supply water connection
8. PTC electric preheater
9. Temperature and humidity sensor T2

## DESCRIPTION

HUMON is an adiabatic duct type humidifier intended for humidification of supply air in small and medium-sized spaces, such as family houses, flats and offices. Humidification is based on natural evaporation processes. Suitable power supply, fresh water connection and wastewater trap should be provided by the Customer. In all cases, the device should be installed in the ventilation system's supply air duct between the HRV unit and the air outlet to the premises. The purpose of the HUMON device is to ensure continuous humidification of the supply air in the ventilation system. The air passing through the evaporating media becomes more moisturised and slightly cooled due to the adiabatic humidification process. The water filter integrated in the HUMON humidifier cleans the water, removing Legionella bacteria. The ionisation device helps to clean the supply air from viruses and bacteria. All the integrated safety equipment guarantees the safe and healthy operation of the device. The HUMON humidifier is made of aluminium zinc-coated steel sheets (corrosion class C4-M/C3-H). It can be installed in premises with a temperature range from +5 to +40°C.

## TECHNICAL DATA

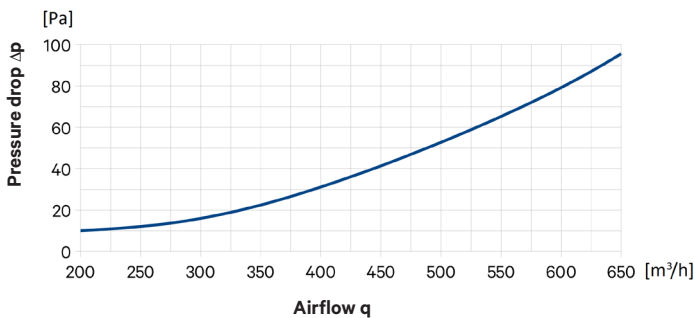

## TECHNICAL DATA

| Description                 | Parameters                                                                                                                           |
|-----------------------------|--------------------------------------------------------------------------------------------------------------------------------------|
| Dimensions WxHxL            | 415 x 345 x 354 mm                                                                                                                   |
| Air duct connections        | Ø250 mm                                                                                                                              |
| Humidification capacity     | 0-4,8 l/h                                                                                                                            |
| Power supply                | 230 V/50 Hz                                                                                                                          |
| Rated current               | 12,1 A                                                                                                                               |
| Rated power, total          | 1400 W                                                                                                                               |
| Energy consumption          | 6,5 W in stand by mode<br>10 W during humidification and ionisation<br>700-1400 W when the heater is operating                       |
| Water consumption           | 0-7,5 l/h (depending on set points)                                                                                                  |
| Water supply connection     | ¾ internal thread with a connection to a 4 mm tube                                                                                   |
| Water drain tray connection | ½ thread adapter to the 16 mm spiral drainage tube                                                                                   |
| Operating air volume        | 200-700 m³/h                                                                                                                         |
| Weight                      | 11,7kg                                                                                                                               |
| Water quality               | Hardness < 8,5 dGH, 5 mg-eq/l, TDS < 350 ppm                                                                                         |
| Factory settings            | Supply air settings 50%, 18°C<br>Indoor humidification up to 45%<br>Start-up is triggered by the outdoor air temperature below +12°C |

### Factors affecting indoor air moisturisation:

- Outdoor humidity and temperature
- Type of HRV unit
- Supplied air volume
- The relative humidity and temperature settings for the supplied air
- Interior finishing and furniture materials
- Ventilation system operation features
- Water temperature

# ADIABATIC DUCT TYPE HUMIDIFIER HUMON H250



HUMON ensures humidification of the supply air under pre-defined parameters in the ventilation system. The recommended reference values for relative humidity are established in the national Hygiene standards. The desired relative humidity values are easily set in the device control system.

## SAFETY AND CONNECTION FUNCTIONS

- PTC heater with automatic overheating protection
- Airflow sensor for start/stop humidifier
- Additional on/off dry contact
- 0–10 V external start-up input
- Option to connect pressure relay for airflow indication
- Option to connect external humidity regulator
- External extract air humidity sensor T4

## ADVANTAGES

- Quiet operation. The humidifier components reduce the noise level in the supply air duct by an average of 5 dB(A)
- The supplied air is humidified up to the relative humidity of 75%. (The humidification intensity depends on the outdoor air temperature and humidity in the supply duct after the HRV unit)
- Built-in PTC air preheater ensures adiabatic humidification process conditions
- Touch-type control panel for convenient parameter setting
- Integrated water filter to trap Legionella bacteria
- Bipolar ionisation device for air purification from viruses and bacteria
- Removable stainless steel drain tray for hygienic operation
- Inspection door with a locking handle for easier maintenance
- Housing made of aluminium zinc-coated steel sheets for high corrosion protection

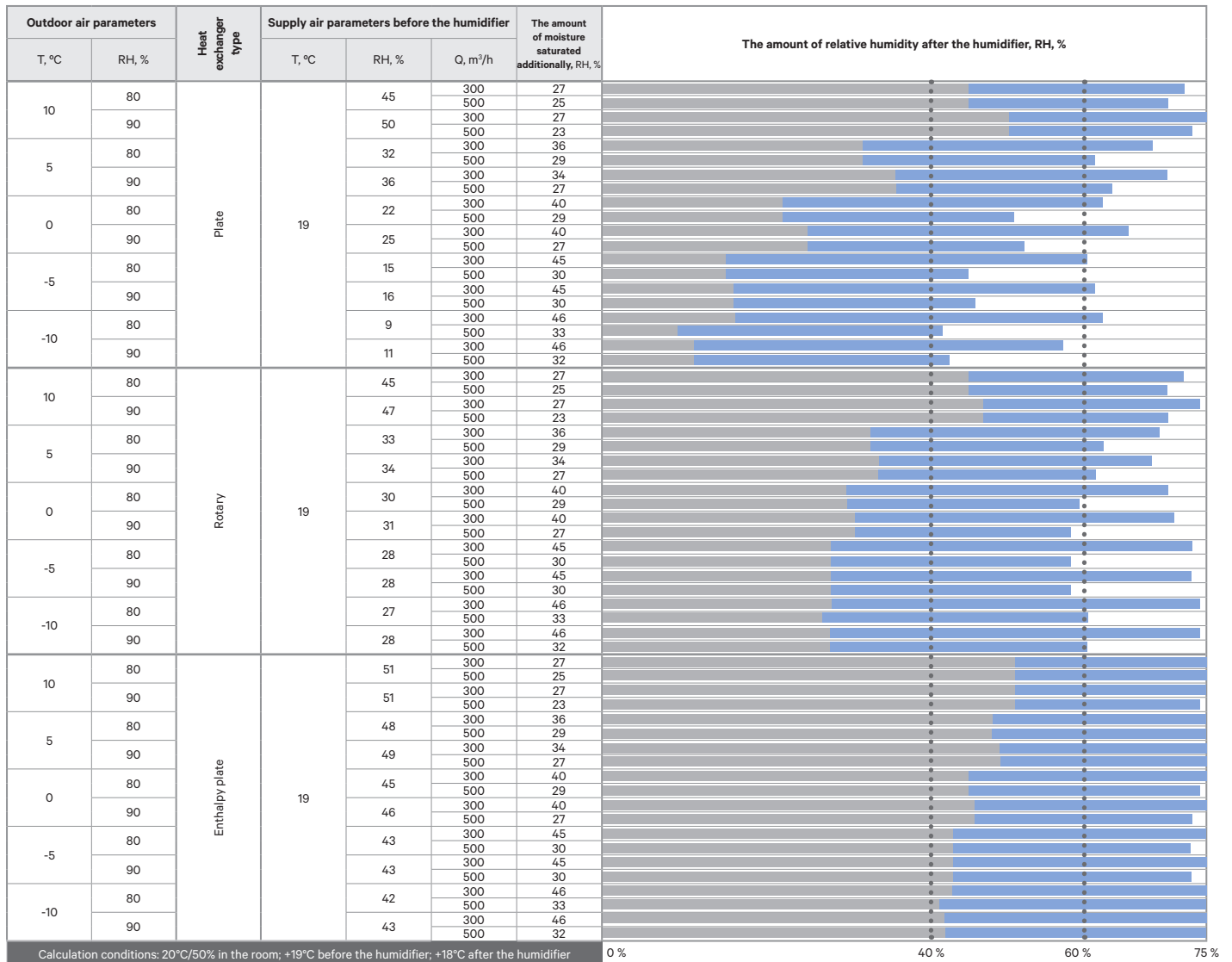

Marking: T, °C air temperature; RH, % relative humidity; Q, m³/h air quantity. Note: when the amount of relative humidity after the humidifier is up to 75%, the intensity of humidification automatically reduces.



Tested and certified  
The device complies with the  
EMC Directive (2014/30/EU)  
and Low Voltage Directive  
(2014/35/EU).



To find out more visit:  
[www.humon.it/en](http://www.humon.it/en)



Manufacturer:  
UAB MK Technika  
[www.mktechnika.lt/en/](http://www.mktechnika.lt/en/)