

ETA K 3500 F OOJR

171665

- Flat air handling unit with counter flow heat exchanger
- Ceiling mounting, version right
- Frameless, double wall housing made of galvanized steel sheet, insulated
- Constant air flow EC fans, integrated controls
- Automatic summer bypass
- Without heating, without cooling, panel filter F7/M5
- Constructed acc. to VDI 6022

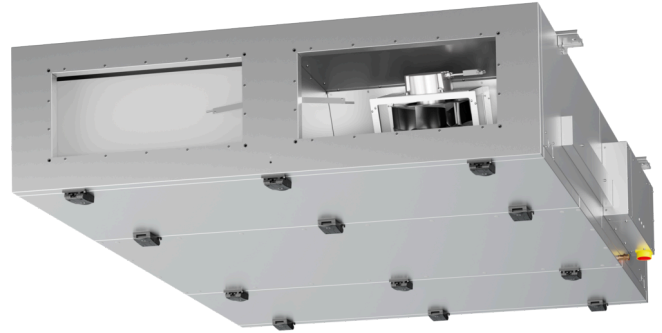

to the product detail page

ETA K 3500 F 00JR

171665

MAP

Name	Value	Unit
Volume flow	0	m³/h
Pressure	0	Pa

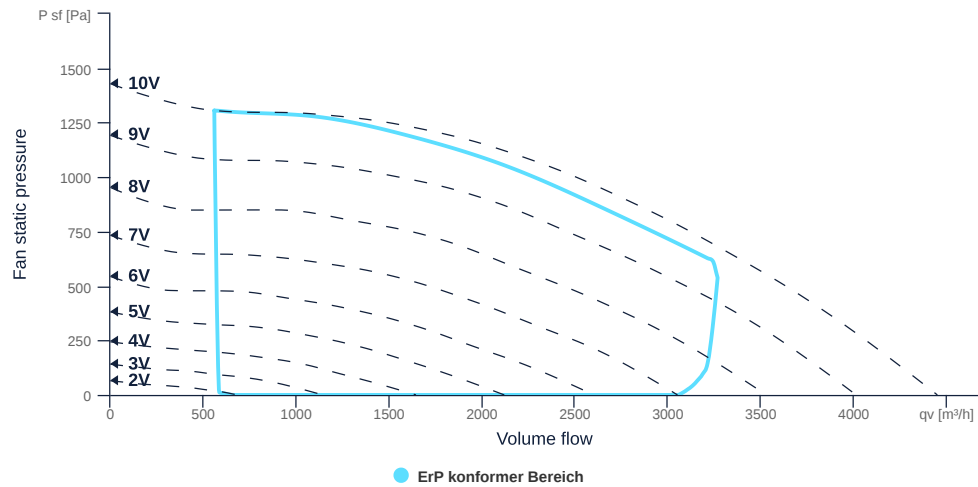

EXTRACT AIR MAP

Name	Value	Unit
Volume flow	0	m³/h
Pressure	0	Pa

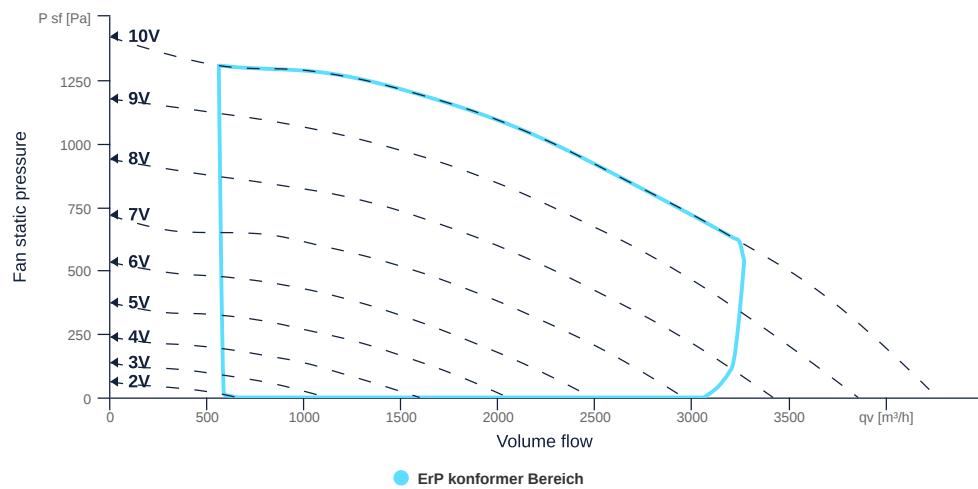

to the product detail page

ETA K 3500 F OOJR

171665

ruck

GENERAL DATA

Name	Value	Unit	Formula symbol
Labeling	CE, UKCA		
Duct size	700x400		WxH _{duct}
Rated voltage (entire device)	400	V	U _{rated}
Phases (entire device)	3-N		phase
Electrical protection (entire device)	6 A		fuse
Housing material	Galvanized steel		mat _{casing}
IP-protection class (casing)	IP41		IP _{casing}
IP-protection class (entire device)	IP41		IP _{compl}
IP-Protection class (terminal box)	IP44		IP _{ebox}
Weight	402	kg	m
Nominal air flow rate, nominal point m³/h	2898	m³/h	q _{nom}
Nominal external pressure, static	200	Pa	p _{s,nom}
Connection side supply air	Right		L/R
Type of the ventilation-unit	BVU - supply air		AHU _{type}
Type of heat-recovery-system	regenerative		HRS _{type}
Type of the heater	No		H _{type}
Type of cooler	No		C _{type}
Outdoor installation	No		outdoor
Leak class	L2		L _{class}
Speed control	variable speed control		VSD _{type}
Filter class extract air	ISO ePM10 50%		F _{class, eta}
Filter class supply air	ISO ePM1 55%		F _{class, sup}
Mechanical stability class	D2		D _{class}

to the product detail page



ETA K 3500 F 00JR

171665

ruck

ERP DATA (LOT 6)

Name	Value	Unit	Formula symbol
Energy performance supply air filter		E	
Energy performance extract air filter		E	
Thermal efficiency HRS, Nominal-point	84.9	%	tNRVU
Nominal air flow rate, nominal point m ³ /s	0.81	m ³ /s	q _{v,nom}
Actual electrical input power, nominal point	1.41	kW	P _{e,nom}
Internal specific fan power, nominal point	1061.67	Ws/m ³	SFP _{int}
Face velocity, nominal point	3.15	m/s	V _{nom}
Nominal external pressure, static	200	Pa	p _{s,nom}
supply air fan static efficiency, nominal point	54.63	%	η _{es,SUP}
static efficiency of the extract fan, nominal point	60.98	%	η _{es,EHA}
Highest external air leakage rate	0.67	%	
Enclosure sound level, nominal point	66.77	dB(A)	LWA2
Rating	Product is compliant 2018		
Internal pressure drop of ventilation components supply air, nominal point	277.03	Pa	dp _{vent,nom,int,SUP}
Internal pressure drop of ventilation components extract air, nominal point	338.21	Pa	dp _{vent,nom,int,EHA}

MAXIMAL DATA

Name	Value	Unit	Formula symbol
Max. power consumption (device)	3000	W	P _{ed,max}
Max. operating current (device)	4.7	A	I _{ed,max}
Max. speed	3800	1/min	n _{max}
Max. stat. efficiency	43.6	%	η _{es}
Max. fan efficiency	43.8	%	η _e
Max. flowrate	4450	m ³ /h	q _{v,max}
Max. stat pressure	1430	Pa	p _{sf,max}
Max. medium temperature	40	°C	T _{m,max}
Max. environment temperature	40	°C	T _{amb,max}
Min. environment temperature	-20	°C	T _{amb,min}

FILTER DATA

Name	Value	Unit	Formula symbol
Degree of separation (supply air)	55	%	
Degree of separation (extract air)	50	%	
Filter group (extract air)	ISO ePM10		
Fitter group (supply air)	ISO ePM1		



to the product detail page

ETA K 3500 F OOJR

171665

CIRCUIT DIAGRAMS / DIMENSIONAL DRAWINGS

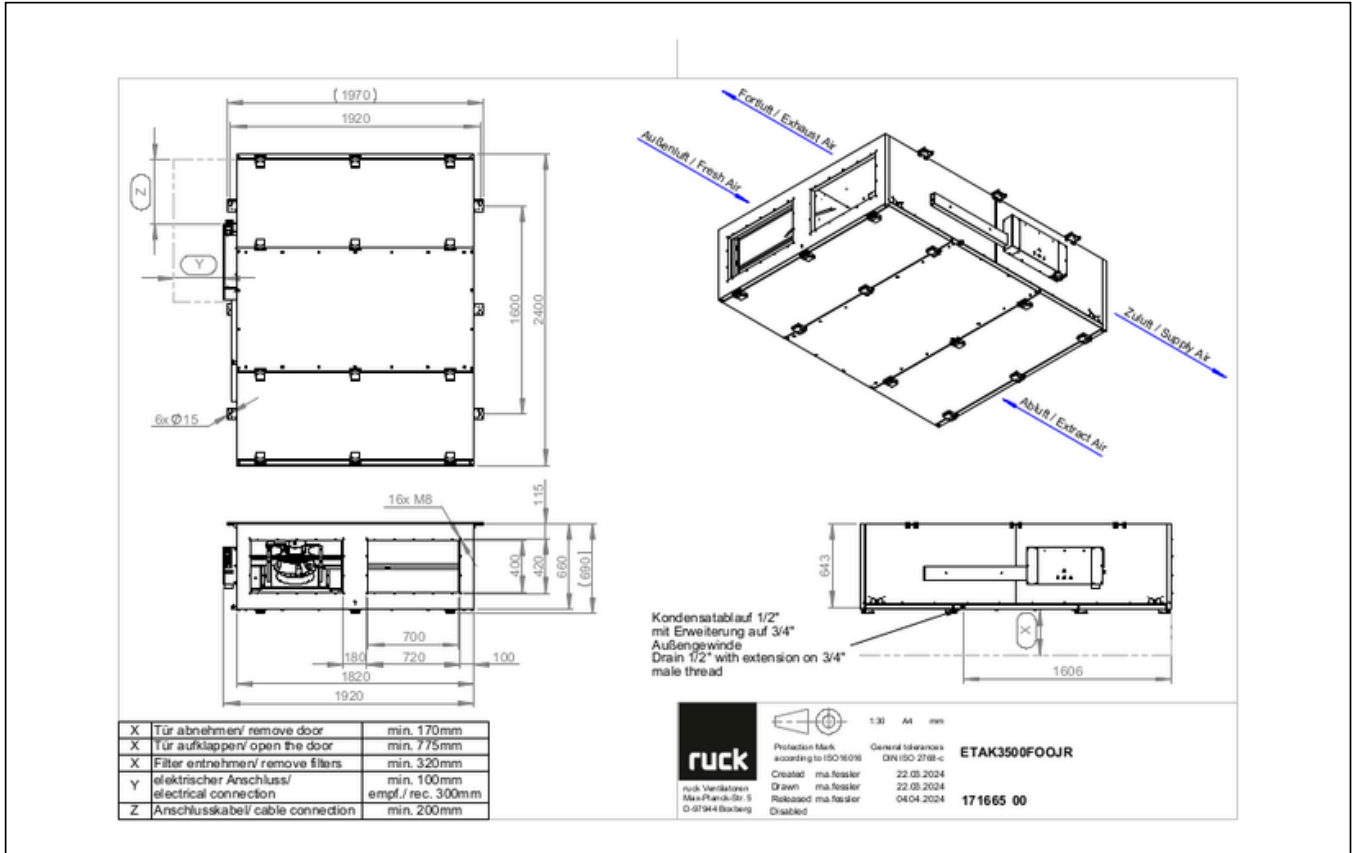

ETA K 3500 F OOJR

171665

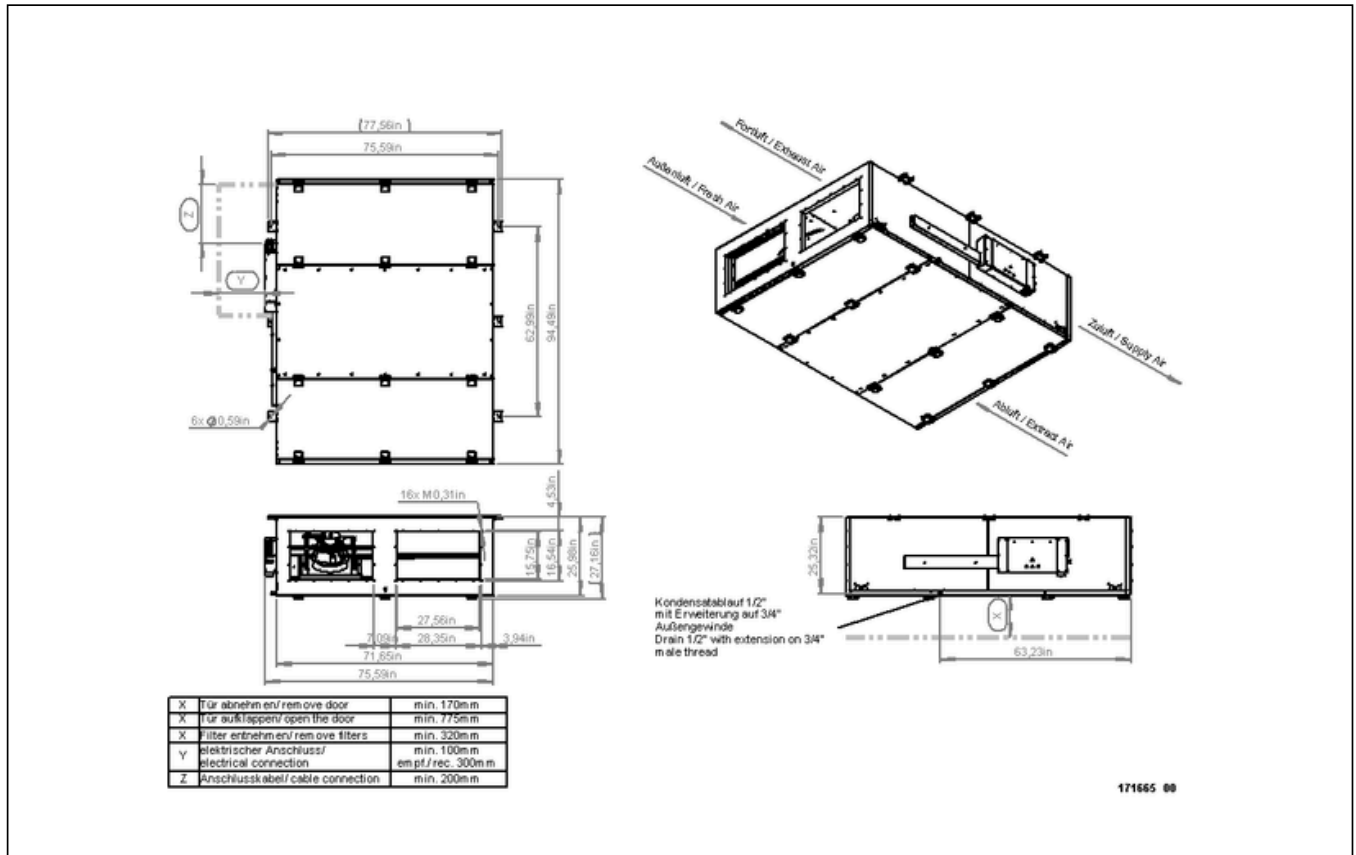

ETA K 3500 F OOJR

171665

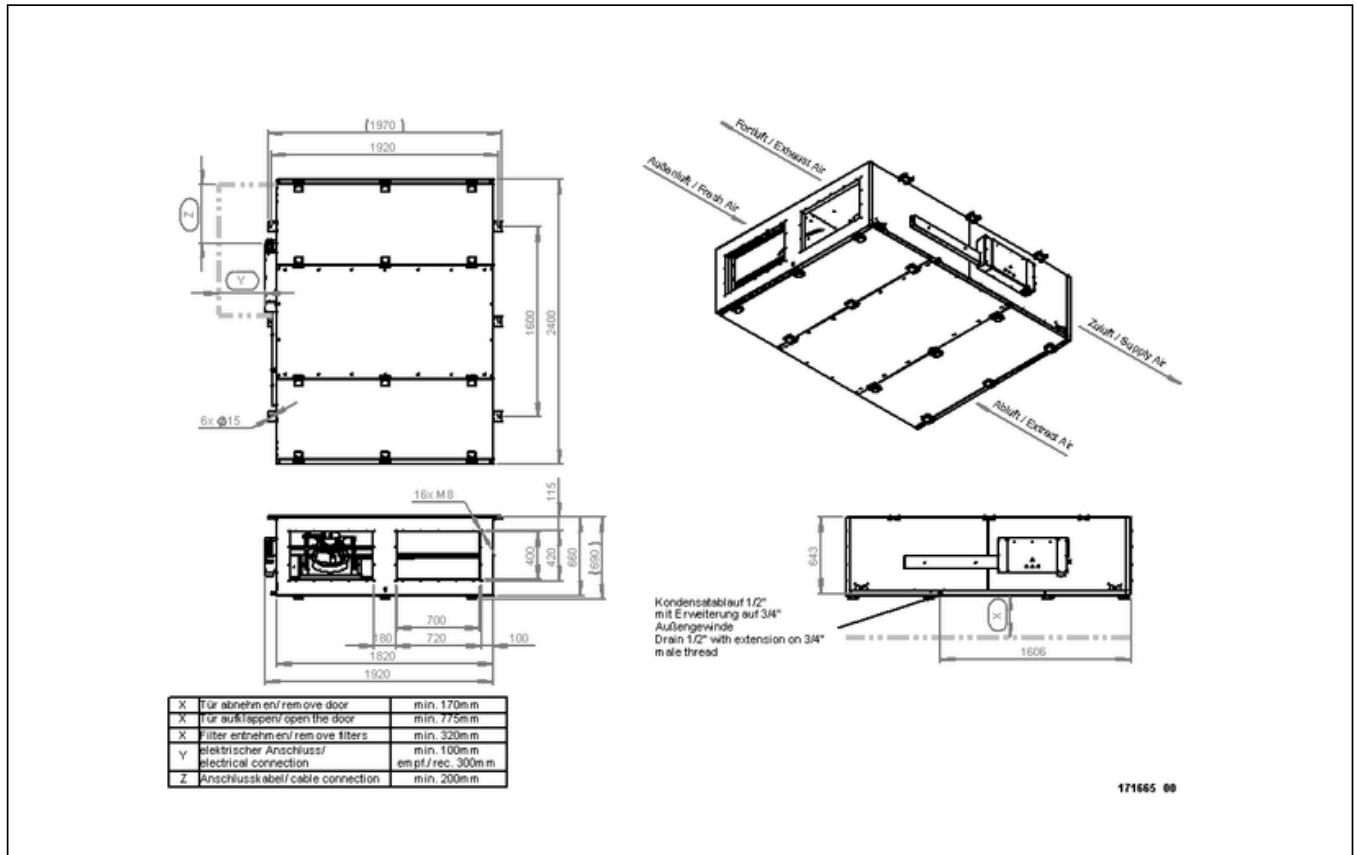

ETA K 3500 F OOJR

171665

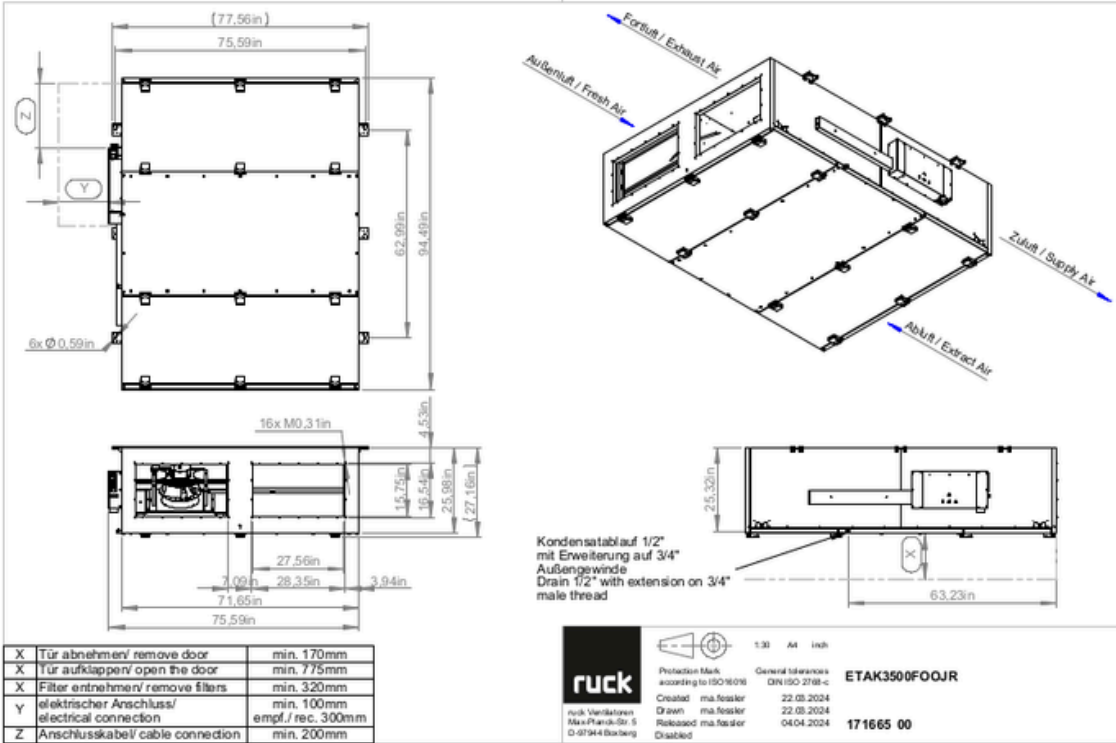

to the product detail page