

WHS



CE

IT	Manuale Specifico.....	2
EN	Specific Manual.....	12
FR	Manuel spécifique.....	22

aerauliqa[®]

WHS RANGE

Ceiling High Volume Low Speed Fan (HVLS)

INDEX

1. GENERAL INFORMATION	12
2. PRECAUTIONS.....	12
3. TYPE	12
4. MAIN FEATURES	13
5. DATA	13
6. DIMENSIONS AND CLEARANCES	13
7. COMPONENTS	13
8. INSTALLATION	14
9. WIRING DIAGRAM.....	17
9.1 CTRL-A (accessory on request)	17
9.2 CTRL-HS (accessory on request)	18
9.3 CTRL-XWS (accessory on request).....	18
9.4 CTRL-XTHI (accessory on request).....	19
9.5 CONTROL WITH EXTERNAL POTENTIOMETER (not supplied).....	19
10. CLEANING.....	20
11. TROUBLESHOOTING.....	20
11.1 Connection parameters.....	20
11.2 Modbus registers - Input registers.....	20
11.3 Alarm codes / led status / troubleshooting.....	20
12. DECLARATION OF CONFORMITY AND INCORPORATION.....	21

1. GENERAL INFORMATION

Carefully read the instructions contained in this manual.

This Specific Manual MUST be read in conjunction with the “Installation, Operation and Maintenance General Manual”.

Note: store the manual for future reference. We reserve the right to improve and make changes to the manual, products and accessories without any obligation to update previous productions and manuals.

The installation and service of the unit and complete ventilation system must be performed by an authorized installer and in accordance with local rules and regulationid.

2. PRECAUTIONS

In addition to the precautions indicated in the “Installation, Operation and Maintenance General Manual” special attention should be paid to the following warning notes:

-The fan must be installed at a height of not less than 2.7m from the floor below. Installation at a lower height is considered “improper use”. In case of “improper use” the manufacturer declines all responsibility for any damage that may be caused to persons or property, and any warranty will be considered invalid.

RECOMMENDED BOLT TORQUE FOR COARSE THREADED METRIC STEEL BOLTS TE-TCEI GRADE 8.

Dimensions	M6	M8	M10	M12	M14	M16
Nm	9,5	23	46	79	127	198

Table 1 Use the values shown in the table to tighten all the screws.

- fixing: check/inspect and eventually retighten all the fixing annually.
- windy conditions: fans should not operate in case of strong wind (6m/s) and should not be installed in places where it is frequently windy.
- weight: it is recommended that the building structure is capable to bear approx. twice the weight of the fan as well as a torque of at least 350Nm. A professional structural engineer should perform an evaluation before installing the fan.
- key safety features: make sure that all the supplied key safety features are used to install the fan to provide a comprehensive protection of people, animals, equipments and property.

The installer and the building owner are responsible to ensure the safety of the fan mounting system and that the fan installation is correct, in compliance with any national and local regulations.

3. TYPE

Ceiling fans with EC brushless motor designed for industrial, civil and zootechnical applications, where high performance with low rotation speed are required.

4. MAIN FEATURES

- Brushless motor 380-440Vac, 3ph, 50/60Hz, IP55
- Max temperature +50°C
- Speed controllable
- Suitable for S1 continuous service
- Embedded electronic system
- Extruded aluminium blades
- Gearless for silent operation
- Maintenance-free
- Key Safety features
- Simplified electrical wiring connection
- Strong and robust design and manufacturing

5. DATA @400Vac, 50Hz

Model	No blades	Max speed rotation	Max absorbed power	Max Thrust	Max airflow AMCA 230-15			Max airflow AMCA 230-99		
					cfm	m ³ /h	SPI ⁽¹⁾ W/(m ³ /s)	cfm	m ³ /h	SPI ⁽¹⁾ W/(m ³ /s)
WHS400	5	120	0.8	272	113086	192133	15.0	159927	271717	10.6
WHS500	5	105	1.1	366	152319	258791	16.0	215412	365986	11.3
WHS600	5	84	1.4	302	178738	303677	16.6	252774	429464	11.7

(1) max. absorbed power / max. airflow

6. DIMENSIONS AND CLEARANCES

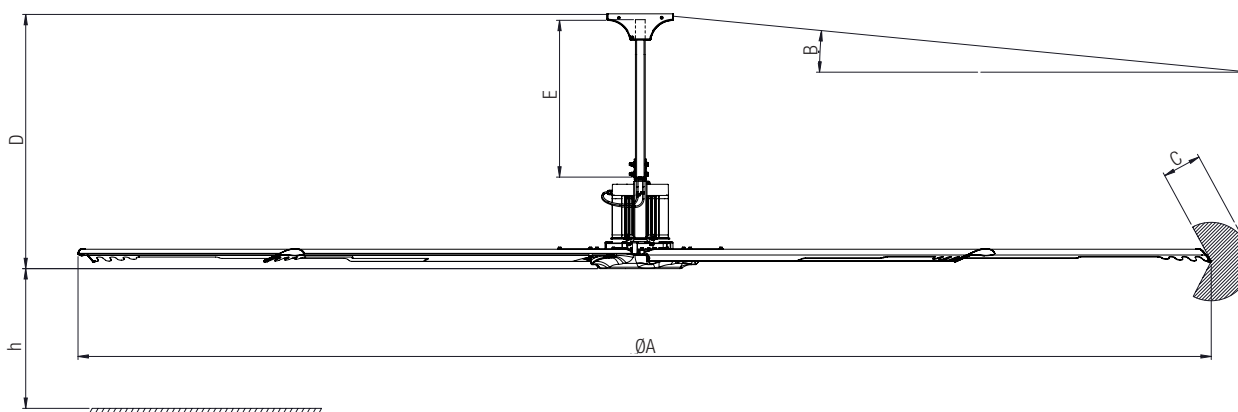

Model	ØA	B max ceiling slop	C min safety distance from side obstacle	D fan height with standard downrod	E standard downrod length	h min fan installation height	Weight
	mm	°	mm	mm	mm	mm	kg
WHS400	4000	20	450	1300	800	2700	105
WHS500	5000		550				127
WHS600	6000		650				143

7. COMPONENTS

- The fan is delivered split into two kits, each one in its own box.
- MOTOR KIT includes:
 - main body (Fig.VIII - 15).
 - standard 800mm length downrod (Fig.II - 6).
 - 2x ceiling fixing brackets (Fig.III - 7 e Fig. IV).
 - 2x fixings sets:
 - 4x M12 bolts (Fig.III and VIII - 8), 4x flat washer (Fig.III and VIII - 9), 4x spring washers (Fig.III and VIII - 10) and 4x locknuts (Fig.III and VIII - 11) for downrod fixing.
 - 10x M8 flange bolts (Fig.XIV - 20), 10x spring washers (Fig.XIV - 21), 10x locknuts (Fig.XIV - 22) and 10x plastic caps (Fig.XIV - 23), to fix the blades to the main body.
 - plastic components set: hub cover (Fig.XV - 24), 5x M4 bolts (Fig.XV - 25), canopy (Fig. VI - 13) and 4x self-tapping screw (Fig.VI - 14).
 - security wires set: 1x Ø5mm 2,5m security wire with one ring (Fig.I and II - 1), 1x Ø5mm 0,35m wire with two rings (Fig.I - 3), 2x 5mm clamp (Fig.V - 12), 2x 7mm snap-hook (Fig.I - 4), 1x shackle (Fig.I - 2) for the security wire; 4x Ø3mm stabilizing wires with turnbuckle (Fig.XI - 16), 4x 5mm snap-hooks (Fig.XI - 17) and 8x 3mm clamp (Fig.XIII - 18), for the stabilizing wires.
- BLADES KIT includes five blades (Fig.XIV - 19).
- The electrical wire type (Fig.II e XVI - 5, not supplied) must comply with the local regulations of the electric system and must have the following features:
 - 4 core supply power cable (one cable section $\geq 1\text{mm}^2$)
 - Multicore control cable (one cable section $\geq 0.5\text{mm}^2$)

Note: the voltage drop cannot be higher than 4%.

8. INSTALLATION

- Decide on the position the fan is to be sited keeping in consideration as follows:
 - the minimum distance from the floor to the lowest point of the fan is 2.7m.
 - the minimum distance from the fan blade to the side wall of similar obstruction depends on the fan model (§ 6 - C).
 - avoid mounting the fan directly below lights to prevent any strobe effect caused by the moving blades.
 - in any installation where fire sprinklers are placed, fan should not interfere with their operation.
 - fan should not be placed near to supply air outlet or exhausting inlets of other HVAC equipment which could decrease the fan capacity and compromise the indoor air quality as well as the occupants' comfort:
 - supply air outlet should deliver air away from the unit.
 - exhaust fan inlets or other return air point which could create negative pressure should not be located within 1,5 times the fan diameter.
 - when mounting the fan, mark the floor with a large crosshatched circle to alert people of the overhead fan location.

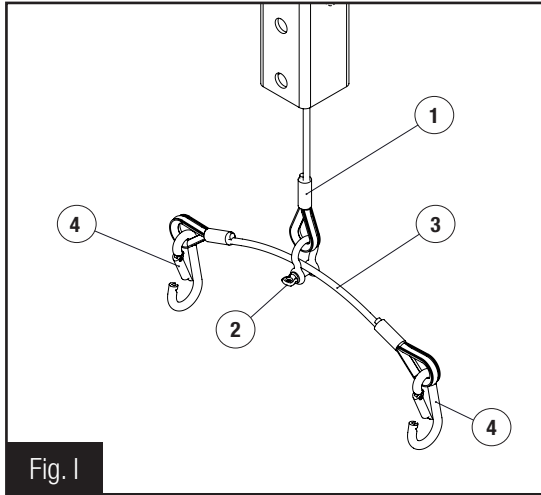

Fig. I

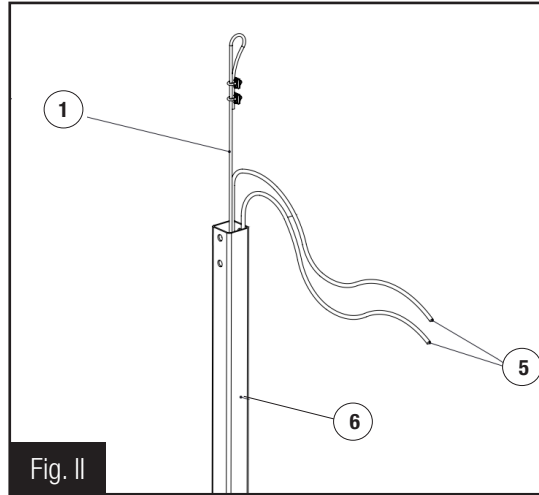

Fig. II

- Compose the security cable set consisting of:
 - Ø5mm wire of 2.5m length (1),
 - 0.33t shackle (2),
 - Ø5mm wire of 0.35m length with two rings (3) and 7mm snap-hook (4).
- Insert the security wire (1) and electric cables (5 - not supplied) into the downrod (6).

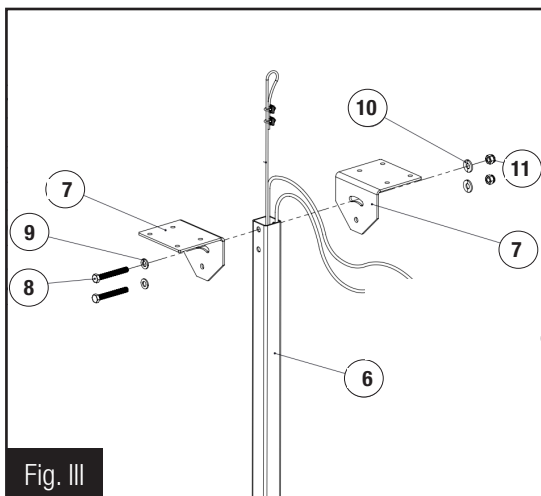

Fig. III

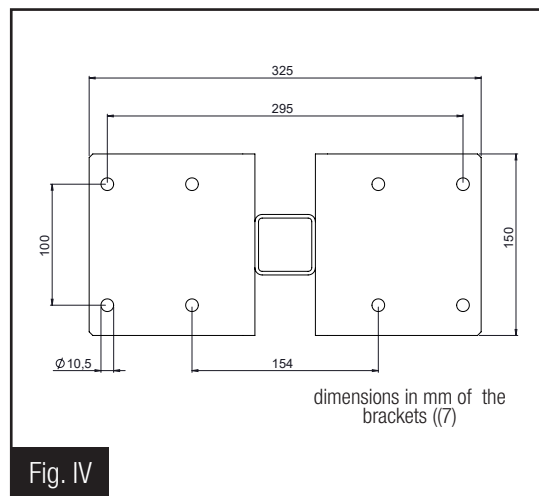

Fig. IV

- Fix the downrod (6) to the ceiling brackets (7) by means of the M12 bolts (8), the flat washer (9), the spring washers (10) and the locknuts (11).

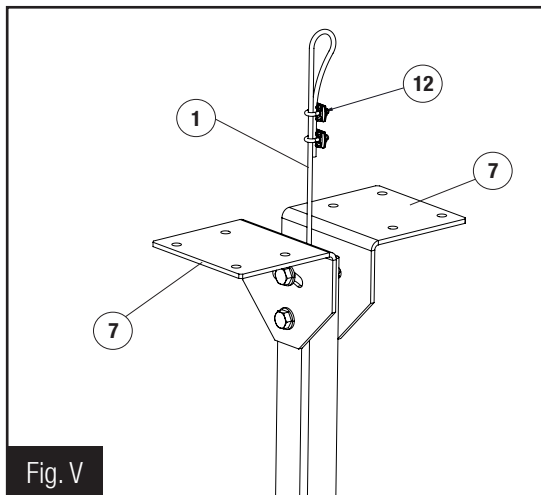

Fig. V

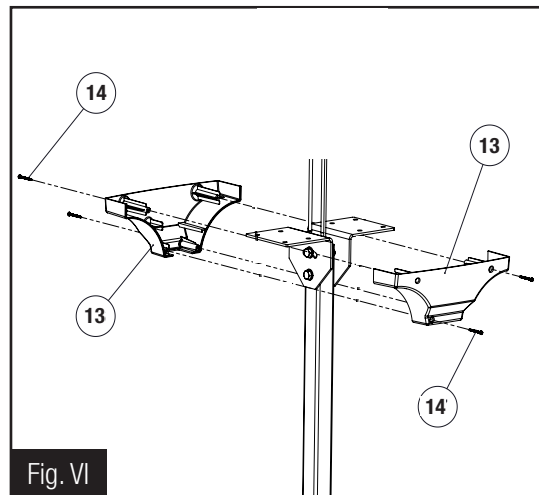
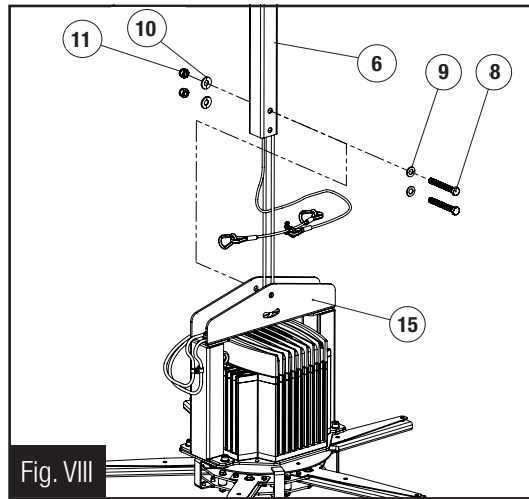
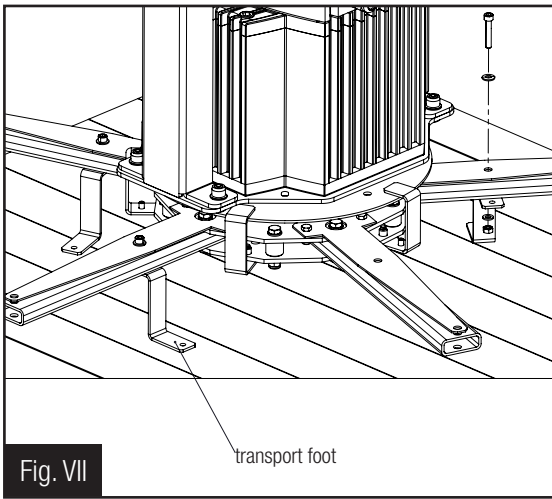
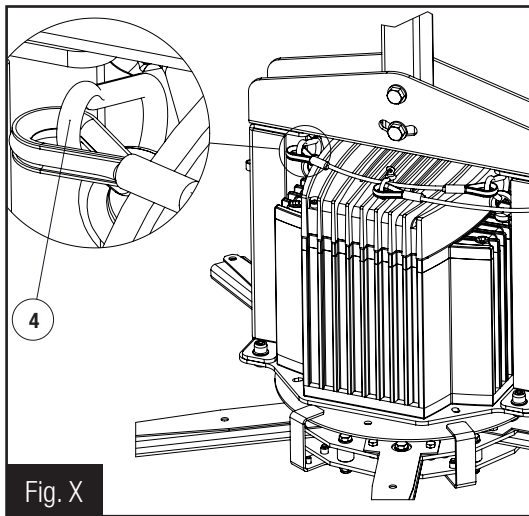
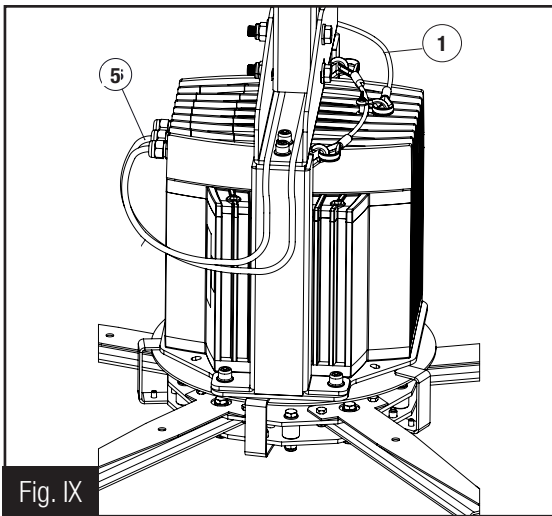

Fig. VI

- Fix the assembly to the ceiling/beam through the 8 holes on the brackets (7) and fix the security wire (1) to the ceiling/beam using the clamps (12). Fixing screws/plugs are not supplied.
- Fix the canopy (13) at the top, using the supplied self-tapping screws (14).



- Remove from the main body the three transport feet (15) (Fig.VII), by unscrewing the bolts, washers and locknuts
- Fix the main body (15) to the downrod (6) using the M12 bolts (8), the flat washer (9), the spring washers (10) and locknuts (11).



- Connect the electric cables (5) to the motor through the front cable grommets, by removing the upper door to access the internal terminal block.
- Let out the safety wire (1) laterally, hooking the snap-hooks (4) to the eyebolts on the motor, verifying the correct tightening.

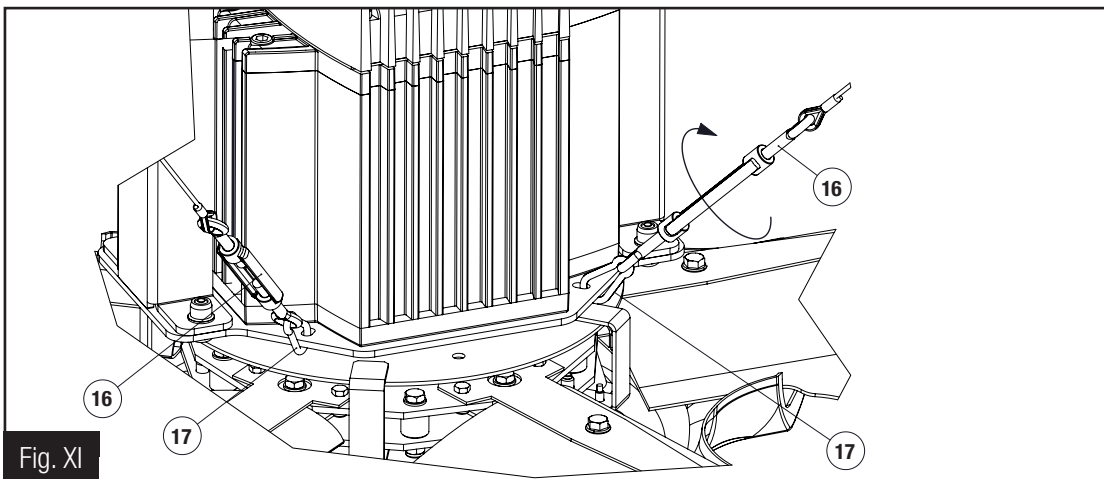

- Connect the $\varnothing 3\text{mm}$ stabilizing wires with turnbuckle (16) to the motor support using the 5mm snap-hooks (17) and stabilise the fan; securely fix the other end of the stabilizing wires to the ceiling using the clamps (18). Fixing screws for the ceiling/beam are not supplied.

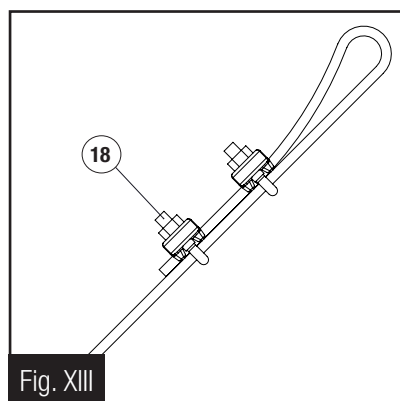
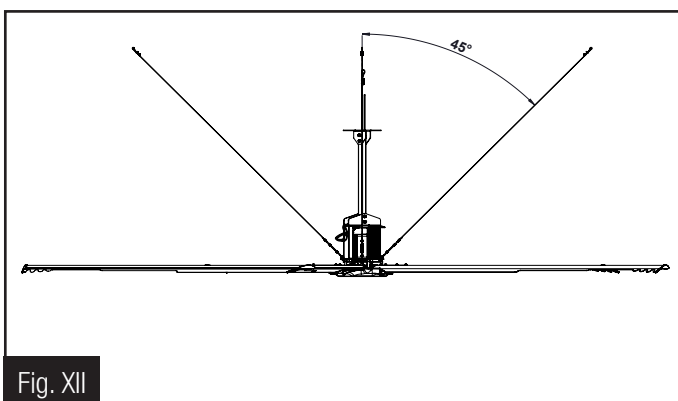

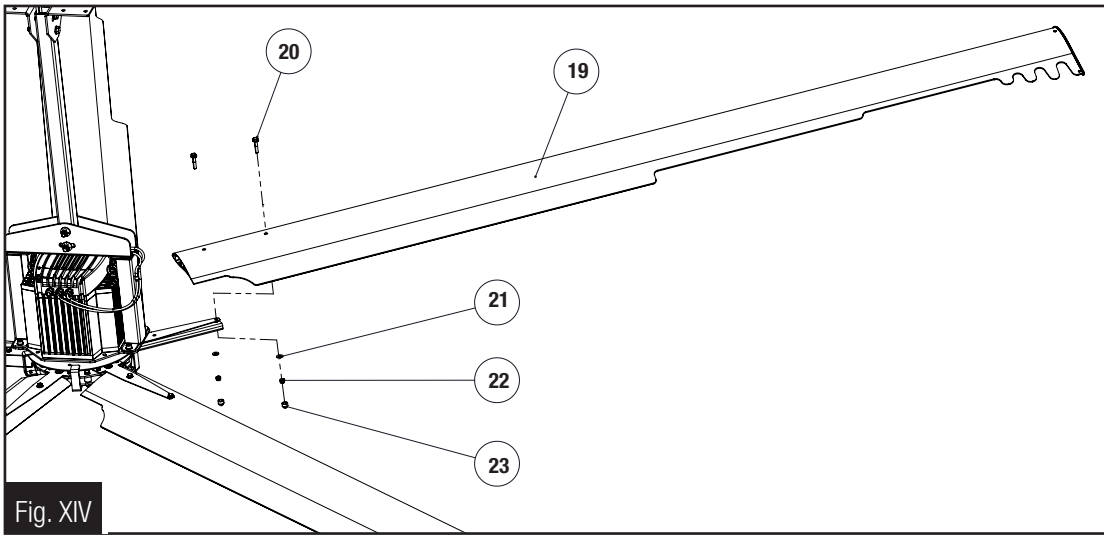

- Insert the blade (19) over the blade root, lock it with the M8 flange bolts (20), spring washers (21) and locknuts (22). Tighten the screws making reference to table 1. Mount the plastic caps (23) on the locknuts. Mount the plastic blade terminals (24) using the appropriate screws (25).

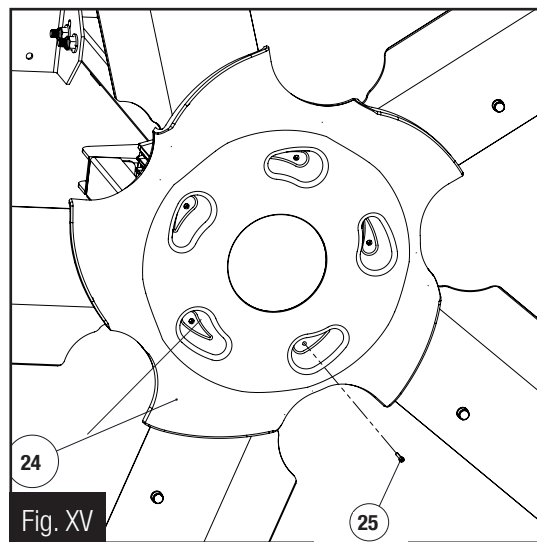

- Mount the plastic cover (24) under the hub using the M4 bolts (25); in case water is used for washing, drill a hole in the plastic cover for water drainage.

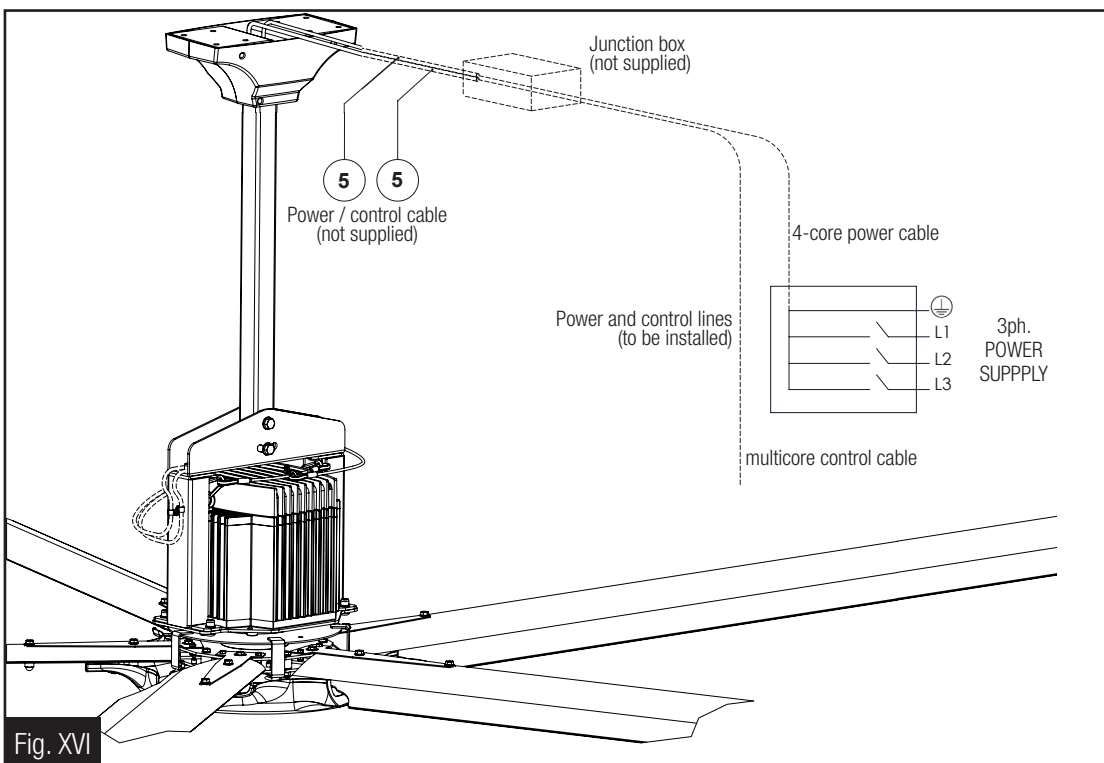

- Make the connection to the power supply/control network by connecting the wired cables (5) to the motor through a junction box (not supplied) to be placed near the ventilation unit. Size the cables appropriately taking into account the distance between the ventilation unit and the power supply point. The complete electrical system must be carried out by a qualified and authorized installer, in accordance with the local requirements.

9. WIRING DIAGRAM

- Make sure that the mains supply to the unit is disconnected before performing any installation, service, maintenance or electrical work!
- The installation and service of the unit and complete ventilation system must be performed by an authorized installer and in accordance with local rules and regulations.
- **Fan must be earthed.**

The fans are supplied with the termination resistor disabled (no bridge between terminals 4 and 6 on the motor board). To reduce possible signal degradation it is recommended to enable the terminating resistor (bridge between terminals 4 and 6 on motor board) of the last fan connected to the communication line. In all cases where this is not necessary or appropriate, it is recommended to check that the terminating resistor is disabled.

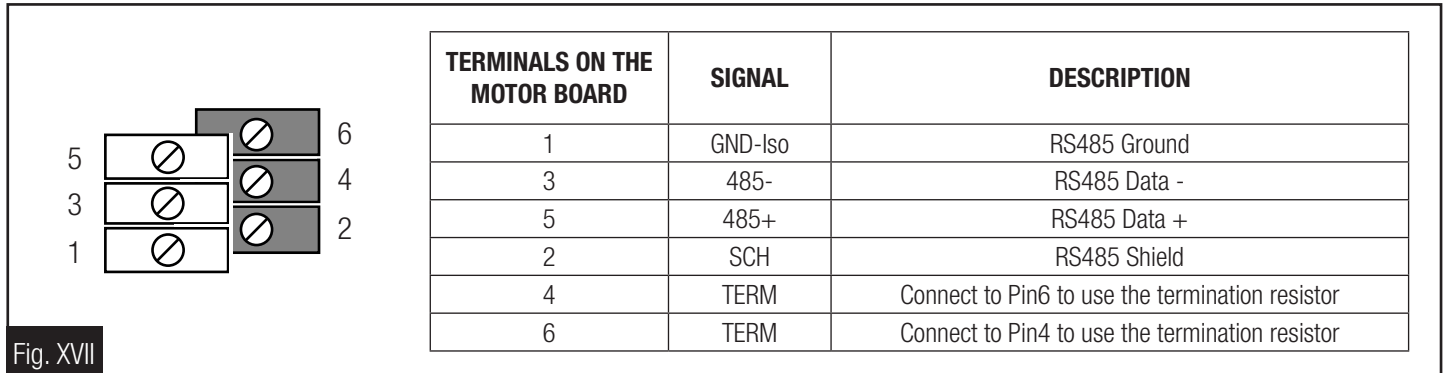
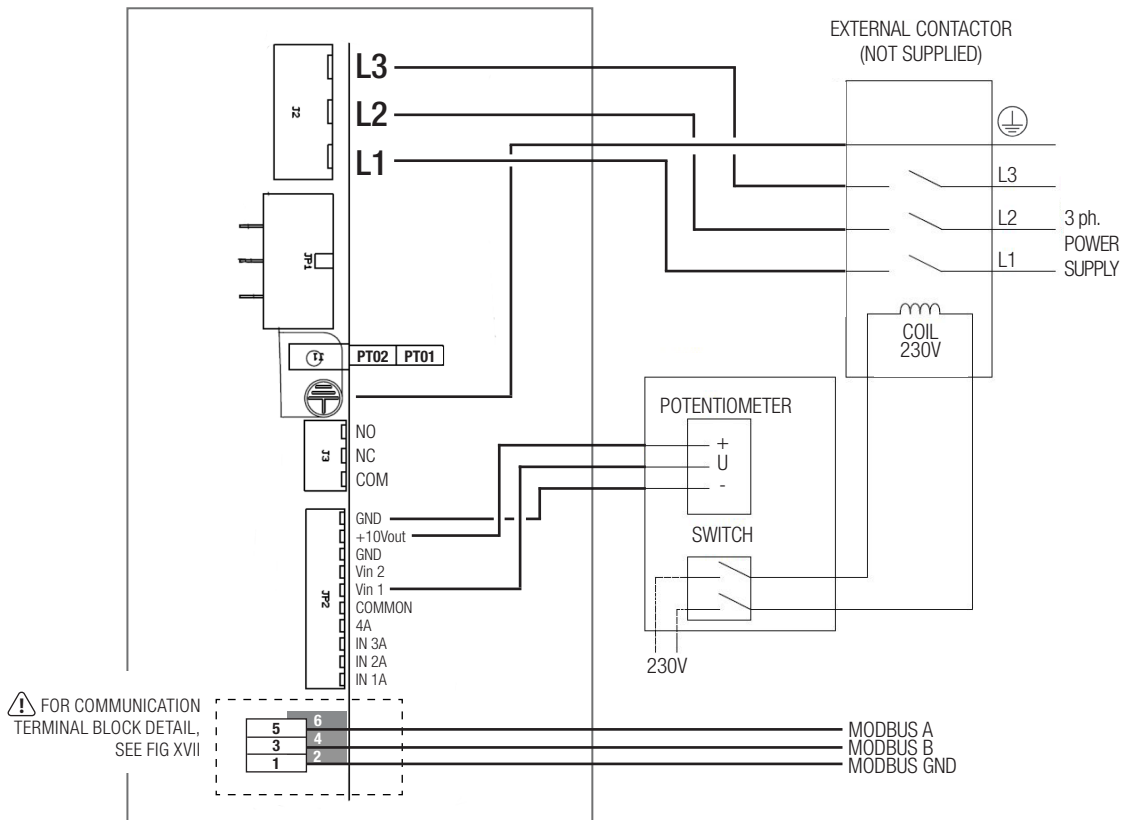

Fig. XVII

WARNING: regardless of the control system in place (analogic or ModBus), it's strongly recommended to wire the ModBus communication line and make it accessible from ground level, in order to ease troubleshooting via ModBus anytime after the installation.

9.1 CTRL-A (accessory on request)



9.2 CTRL-HS (accessory on request)

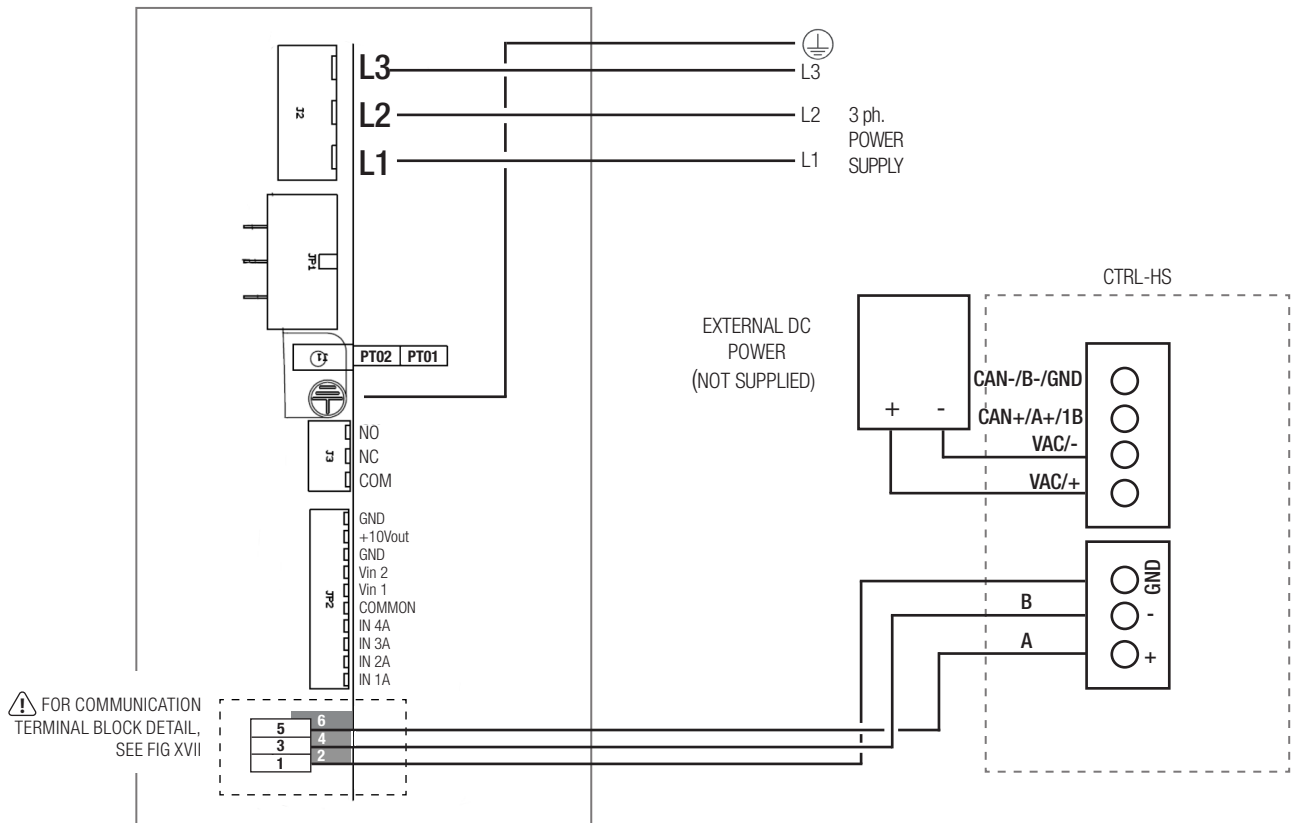

For functionalities, refer to the dedicated manual of the CTRL-HS touch control panel.



9.3 CTRL-XWS (accessory on request)

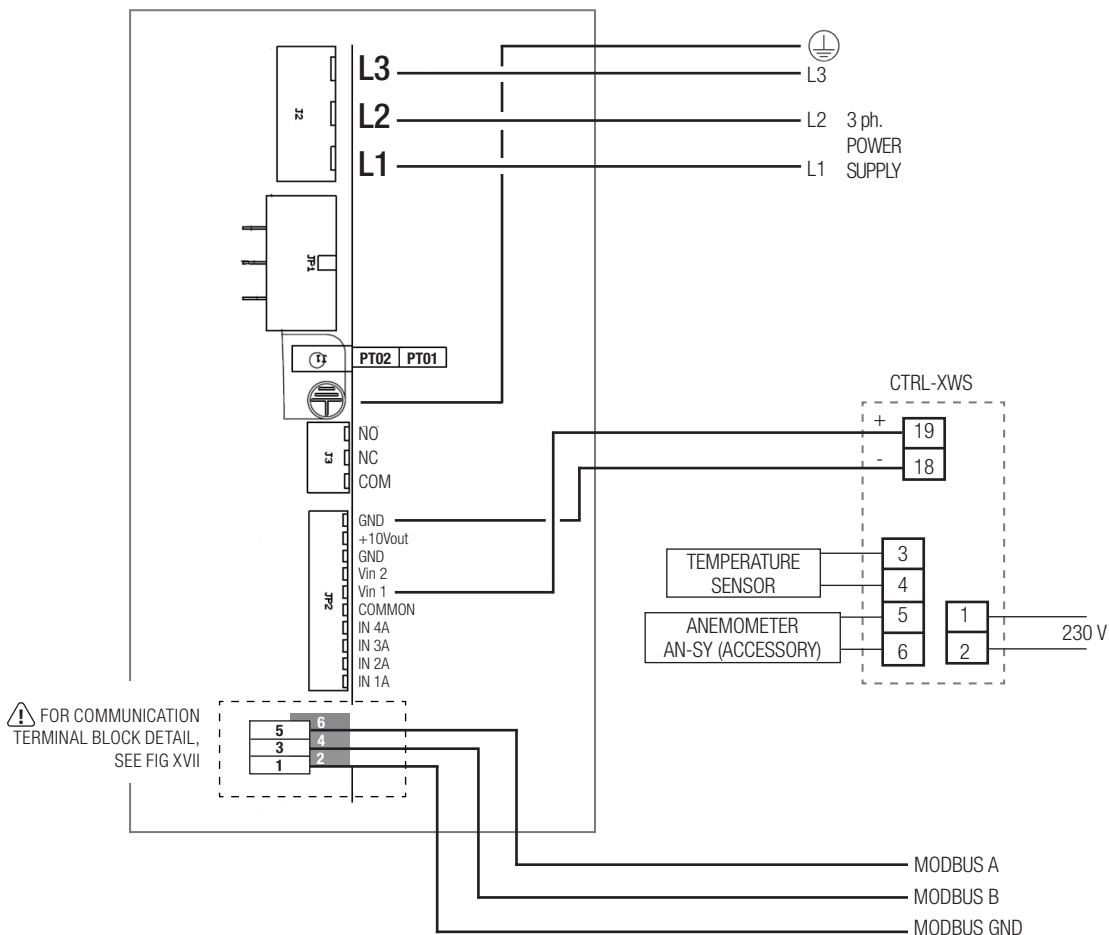

9.4 CTRL-XTHI (accessory on request)

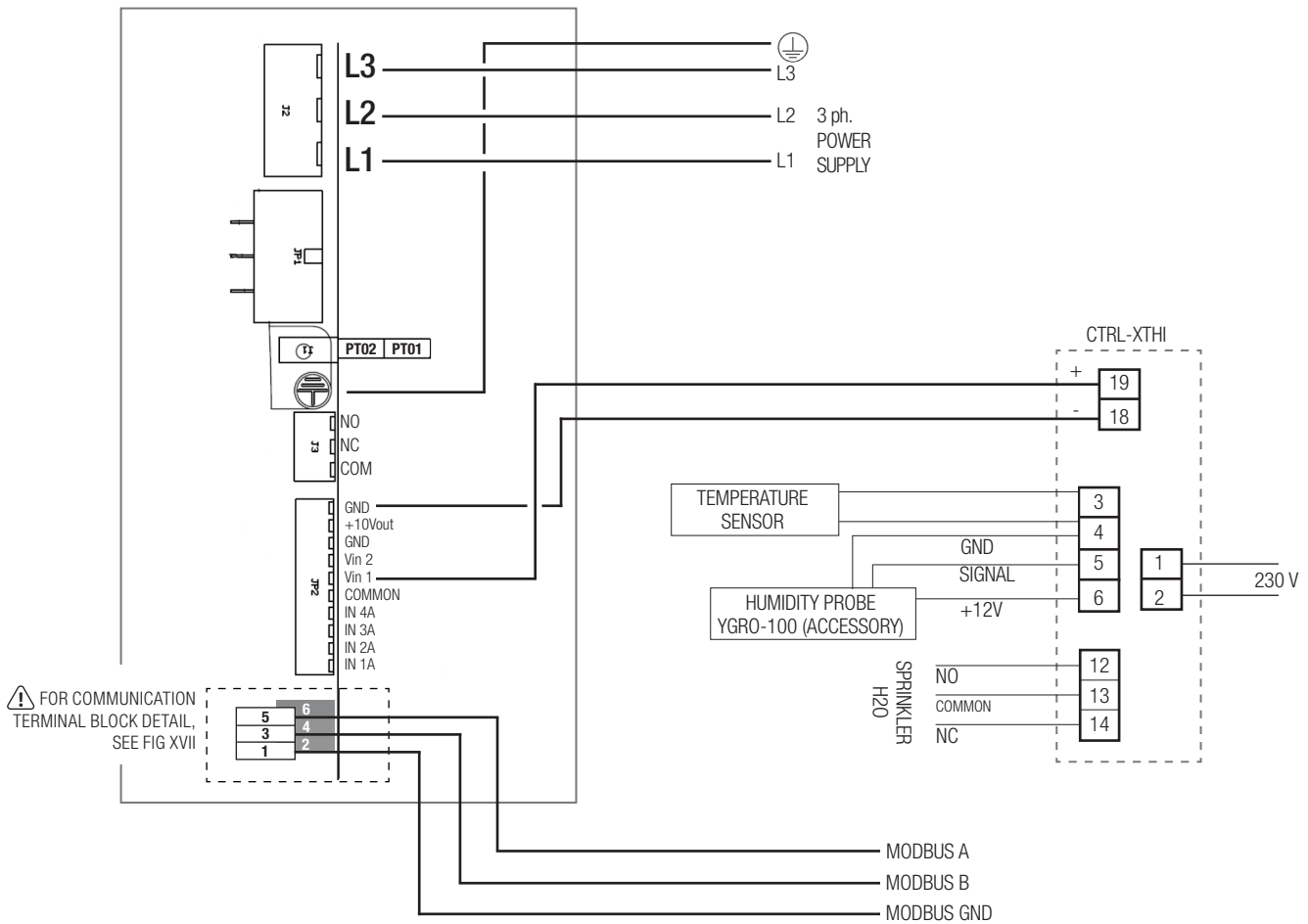

9.5 CONTROL WITH EXTERNAL POTENTIOMETER (not supplied)

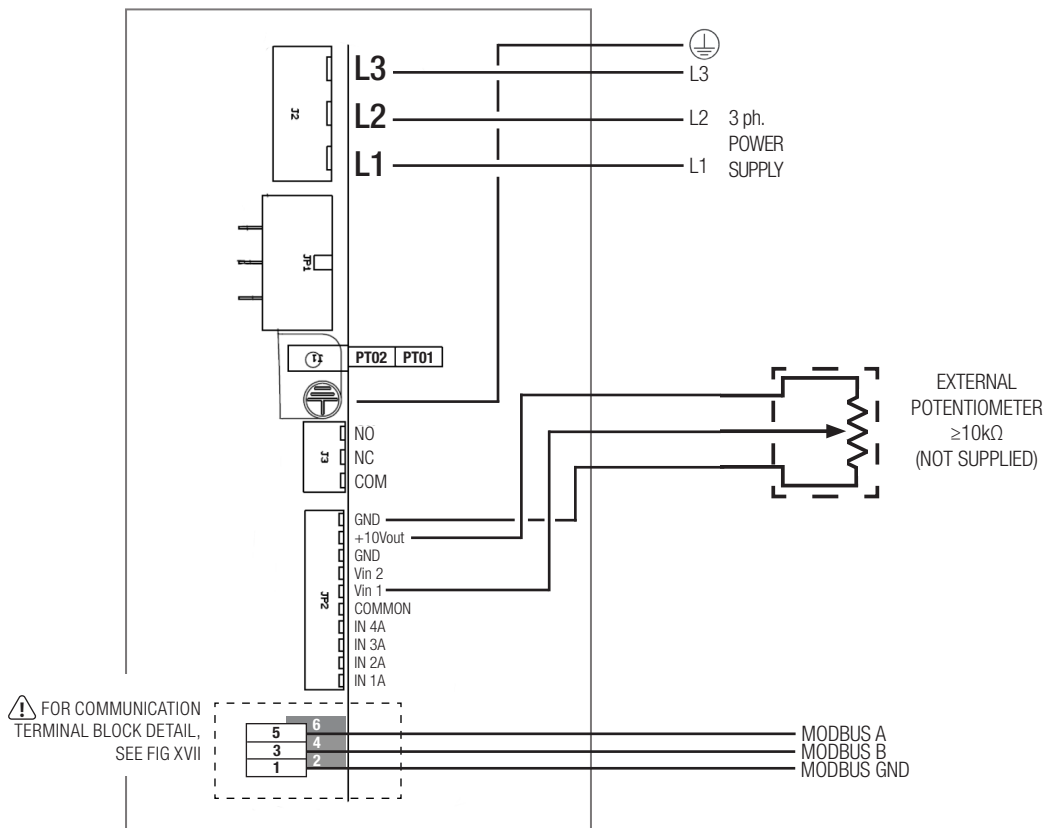

10. CLEANING

The unit (IP55) can be washed with water jets. In this case it is recommended to drill a hole under the plastic hub cover for water drainage.

11. TROUBLESHOOTING (Modbus)

11.1 Connection parameters

Protocol	MODBUS/RTU over RS485
Baud Rate (bps)	9600
Data bits	8
Parity bits	none
Stop bits	2
HVLS Slave Address	1

11.2 Modbus Registers - Input Register

These registers are READ-ONLY, and can be read using the function *04 READ INPUT REGISTERS*.

Register Address	Description	Dimension (Word)	Data Type	U.M. (data on the register)	Example Register value → Real value
3	Measured speed	1	ushort	0.1rpm	490 → 49rpm
10	Alarm 1	1	ushort	-	See table (§ 11.3)
17	Alarm 2	1	ushort	-	See table (§ 11.3)

11.3 Alarm codes/LED status/Troubleshooting

ALARM 1 VALUE	ALARM 2 VALUE	ALARM DESCRIPTION POSSIBLE CAUSE	TROUBLESHOOTING
0	0	No error	-
1	0	Memory error – motor parameters lost	Contact manufacturer/technical support
2	0	Short circuit – electronics power module damaged	Board damaged – replace board
3	0	Motor synchronization lost – wrong motor parameters or electronics damaged	Check motor windings. If motor windings OK (all 3 windings have same resistance), replace board. If motor windings damaged (open/short circuit), replace motor.
4	32	Over voltage: supply voltage above 565Vac (DC bus voltage over 800V) during motor running	Check power supply voltage check power supply wiring
4	33	Under voltage: supply voltage below 212Vac (DC bus voltage below 300V) during motor running	Check power supply voltage check power supply wiring
4	113	Electronics temperature over 85°C (check input register 15)	Check if operating temperature is above rated maximum operating temperature. Check mechanical load for anomalies (e.g. difficult turning)
4	114	Motor windings temperature over 125°C (check input register 16)	Check if operating temperature is above rated maximum operating temperature. Check mechanical load for anomalies (e.g. difficult turning)

For additional information on HVLS Modbus control, contact the manufacturer/technical support.

12. DECLARATION OF CONFORMITY AND INCORPORATION



AERAULIQA SRL
Sedi produttive / Production plants:
Plant A: Via Mario Calderara 39-41
25018 Montichiari, Brescia
Plant B: Via Torquato Tasso
25016 Ghedi, Brescia
Sede legale/Registered office:
Via Mario Calderara 39-41
25018 Montichiari, Brescia
C.F. e P.IVA 03369930981 - REA BS-528635
Tel: 030 674681 Fax: 030 6872149
www.aerauliqa.it - info@aerauliqa.it

AERAULIQA SRL è una società a socio unico, sotto la direzione e coordinamento di Elta Group Ltd (UK)
AERAULIQA SRL is a single-member company subject to management and coordination of Elta Group Ltd (UK)

UE DECLARATION OF CONFORMITY/INCORPORATION

Manufacturer:

AERAULIQA SRL

Via Mario Calderara 39/41 - 25018 Montichiari (BS) - ITALY

UE DECLARATION OF CONFORMITY



We herewith declare that the following range:

WHS series ceiling fans

BRAND: **AERAULIQA**

MODELS:

WHS400, WHS500, WHS600

on the basis of its design and construction as partly completed machines brought onto the market, is designed in compliance within relevant health and safety requirements of the following Directives:

2014/35/UE - Low Voltage Directive (LVD)

2014/30/UE - Electromagnetic Compatibility (EMC)

2009/125/EC - Energy Related Products (ErP)

in the event that alterations are made to the machinery without prior consent with the manufacturer, this declaration becomes invalid.

This declaration is issued under the sole responsibility of the manufacturer.

UE DECLARATION OF INCORPORATION

In accordance with the Machinery Directive 2006/42/EC.

We herewith declare that the following range:

WHS series ceiling fans

BRAND: **AERAULIQA**

MODELS:

WHS400, WHS500, WHS600

on the basis of its design and construction of partly completed machines, is designed in compliance with the Essential Health and Safety Requirements (EHSRs) of ANNEX I, sections 1.1.2 (Safety integration), 1.1.5 (Handling), 1.4.1 (Protective devices), 1.5.1 (Electricity) of **EC Machinery Directive 2006/42/EC**.

The machinery is incomplete and must not be put into service until such time as the machinery which is partly complete is to be incorporated and has been assessed and declared in conformity with the provisions of the Machinery Directive 2006/42/EC.

We undertake to transmit, upon reasoned request by appropriate national authorities, relevant information on the partly completed machinery identified above.

Montichiari, 01/06/2024

Direttore Generale
Ing. Guido Banzi