



CENTRALISED ENERGY RECOVERY UNIT WITH ENTHALPIC HEAT EXCHANGER

APPLICATION

Whole-house heat recovery unit, suitable for vertical installation.

SPECIFICATION

Outer fan casing manufactured from powder coated galvanised sheet steel providing long lasting and robust construction. The unit is finished in white RAL 9010.

Internal structure manufactured from EPP (expanded polypropylene) providing reduced sound emissions and maximised air tightness and thermal insulation.

EC external rotor motors fitted as standard for energy saving. Provided with integral thermal protection, mounted on sealed for life ball bearings.

Backward curved centrifugal impeller dynamically balanced and directly driven by the motor to provide a smooth airflow through the unit.

Enthalpic heat exchanger with high thermal and latent efficiency. Made of antimicrobial technology, the built-in polymer membrane is mould and bacteria resistant: it also prevents the air flows contamination and block the odours.

The special configuration generates low pressure drop.

Very easy to be cleaned.

Average efficiency:

85% thermal;

65% humidity.

FEATURES & BENEFITS

Ease of installation: fixing bracket supplied to hang the unit easily on the wall.

Simplified electric wiring: the unit is supplied pre-cabled.

Removable front panel for quick access to filters and heat exchanger.

Enthalpic heat exchanger suitable to transfer thermal energy and humidity from one airflow to the other, keeping the correct indoor humidity level (40-60%). During winter time, for example, it prevent that indoor air becomes too dry; in summer, instead, the humidity of the outdoor warm air is not transferred to the indoor cool air.

G4 filters easy removable for cleaning. The unit is also provided with the F7 filter accessory at the intake side.

Integral automatic physical bypass for free cooling during the summer season.

Automatic anti-frost protection to prevent frost building up on the exhaust side of the heat exchanger.

No condensation drainage is required.

Left/right configuration of the unit for mounting flexibility.

Tested to the latest standards: units are tested in the TÜV Rheinland accredited internal laboratory at Aerauliqa according to the operating document IEC OD 2048 (level CTF1) for the IEC 60335-1 and IEC 60335-2-80 Standards, meaning accurate, up to date information on electrical safety, performance and noise level that can be relied upon.

Designed and manufactured in accordance with EN60335-2-80 (Low Voltage Directive) and the EMC Directive (Electromagnetic Compatibility).

VERSIONS

The unit is supplied with a multi-function LCD display (CTRL-DSP) for automatic control and convenience, providing:

- 3 speed settings (adjustable).
- Boost option.
- Holiday mode.
- Night mode.
- Weekly timer.
- Bypass setting.
- Airflow balancing.
- Filter replacement and fan failure indicator.
- Working hour counter.
- Setting saving and loading.
- Suitable for remote ambient sensors (SEN-HY, SEN-PIR).
- ModBus interface.
- Connection to remote pre/post heating element.
- Left or Right hand configuration (air connection).



CTRL-DSP
(supplied as standard)

QR590E

Example of a complete ventilation system

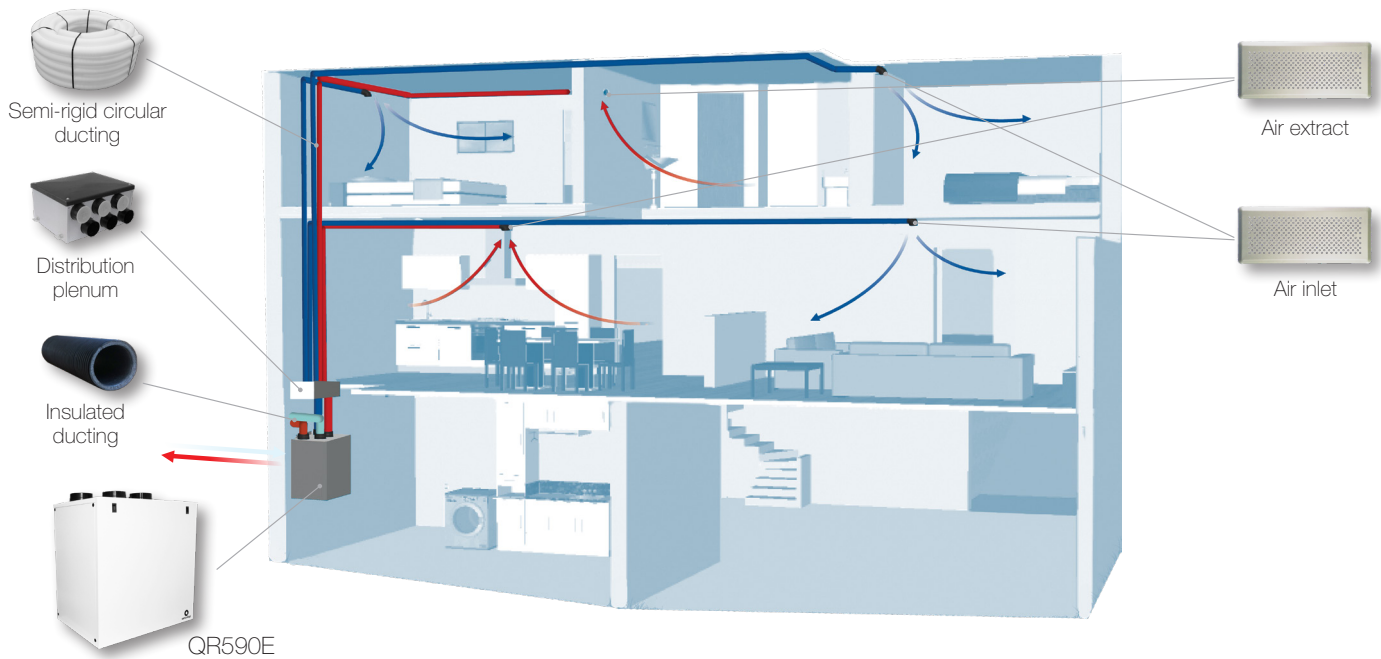

Application: new build.

How it works: a continuous running energy recovery unit (QR590E) transfers thermal energy and humidity from humid air extracted from wet rooms to warm incoming fresh air which is ducted to habitable rooms. Thanks to the easy-to-fit air distribution system each single ambient can be properly ventilate; the boost function enables rapid extract of increased moisture or pollutant levels. It also provides discrete installation and very quite operation. QR590E does not need any condensation drainage.

Energy saving: the preheated/precooled fresh air and continuous air changes reduce the demand for additional heating/air-conditioning. The EC brushless motors significantly reduce the electricity consumption.

Indoor Air Quality: a correctly specified mechanical ventilation system can ensure the quality of the indoor air is constantly maintained for the health and well-being of the occupants as well as of the building. Duly maintained filters ensure that incoming air is suitably filtered of dust and pollen before it enters the home.

Dimensions (mm) and Weight (kg)

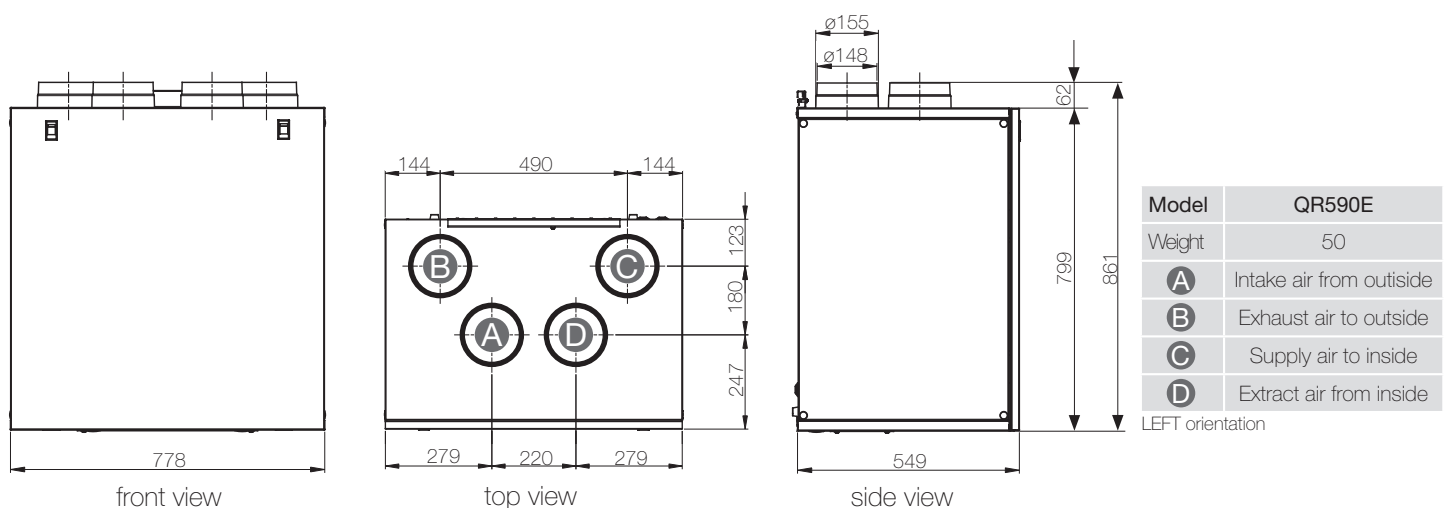

Product fiche - ErP Directive, Regulations 1253/2014 - 1254/2014

a)	Mark	-	AERAULIQA		
b)	Model	-	QR590E		
c)	SEC class	-	A	B	B
c1)	SEC warm climates	kWh/m ² .a	-14,9	-10,8	-7,2
c2)	SEC average climates	kWh/m ² .a	-38,0	-32,9	-28,6
c3)	SEC cold climates	kWh/m ² .a	-73,7	-66,9	-61,2
	Energy label	-	Yes		
d)	Unit typology	-	Residential - bidirectional		
e)	Type of drive	-	Variable speed drive		
f)	Type of Heat Recovery System	-	Heat recovery		
g)	Thermal efficiency of heat recovery	%	71		
h)	Maximum flow rate @ 100 Pa	m ³ /h	561		
i)	Electric power input (maximum flow rate)	W	343		
j)	Sound power level (L _{WA})	dBA	58		
k)	Reference flow rate	m ³ /h	393		
l)	Reference pressure difference	Pa	50		
m)	Specific power input (SPI)	W/m ³ /h	0,344		
n1)	Control factor	-	0,65	0,85	1,0
n2)	Control typology	-	Local demand control	Central demand control	Manual control (no DCV)
o1)	Maximum internal leakage rate	%	0,8		
o2)	Maximum external leakage rate	%	0,5		
p1)	Internal mixing rate	%	N/A		
p2)	External mixing rate	%	N/A		
q)	Visual filter warning	-	Visual filter warning on display		
r)	Instructions to install regulated grilles	-	N/A		
s)	Internet address for pre/disassembly instructions	-	www.aerauliqa.com		
t)	Airflow sensitivity to pressure variations	%	N/A		
u)	Indoor/outdoor air tightness	m ³ /h	N/A		
v1)	AEC - Annual electricity consumption - warm climates	kWh	1,8	3,1	4,3
v2)	AEC - Annual electricity consumption - average climates	kWh	2,3	3,6	4,8
v3)	AEC - Annual electricity consumption - cold climates	kWh	7,6	8,9	10,1
w1)	AHS - Annual heating saved - warm climates	kWh	19,4	18,6	18,0
w2)	AHS - Annual heating saved - average climates	kWh	43,0	41,2	39,8
w3)	AHS - Annual heating saved - cold climates	kWh	84,1	80,5	77,8
	Sound pressure @ 3m ⁽¹⁾	dB(A)	34		
	Ambient temperature max	°C	+40		
	Degree of protection IP	-	X4		
	Marking	-	CE		

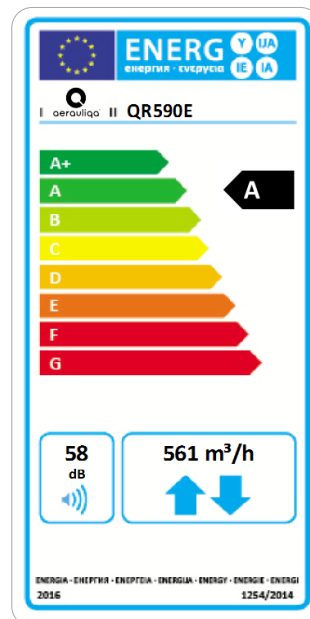

- 220-240V ~ 50/60Hz.

- air performance measured according to ISO 5801 a 230V 50Hz, air density 1,2Kg/m³.

- data measured in the TÜV Rheinland accredited internal laboratory at Aerauliqa according to the operating document IEC OD 2048 (level CTF1) for the IEC 60335-1 and IEC 60335-2-80 Standards.

(1) sound pressure level @ 3m in free field, breakout, speed 40%, for comparative purposes only.

QR590E

Performance curve

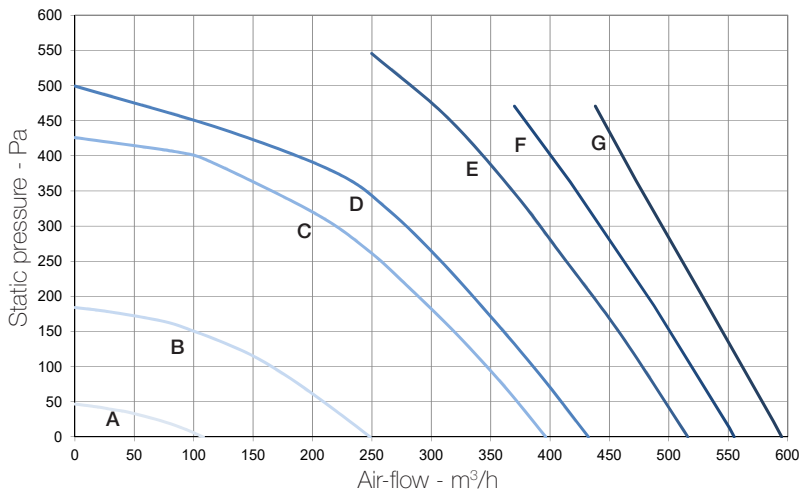

Curve	Speed %	W max	m³/h max
A (min)	21	11	108
B	37	38	249
C	54	117	396
D	58	146	432
E	67	234	516
F	81	305	555
G (max)	100	343	595

Intake curve according to Reg. 1253/2014 (ErP).
Product tested without filter F7.

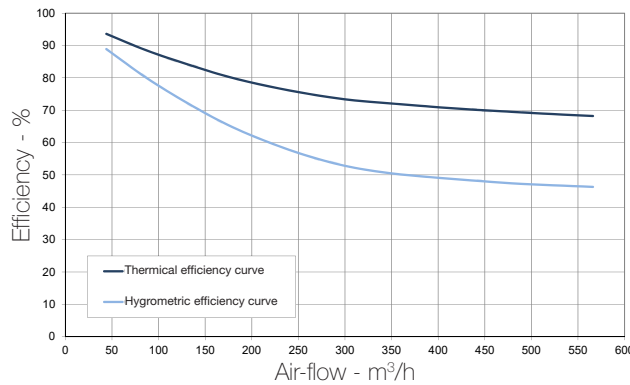

Data of the enthalpic heat exchanger.
Test conditions:
Indoor air 25°C 50% RH;
External air 5°C 70% RH.

Sound level

	Speed 100%	Lw dB - SOUND POWER OCTAVE BAND									Lp dB(A)
		63	125	250	500	1 K	2 K	4 K	8K	Tot	@3m
Intake		83	65	70	73	62	58	53	47	84	51
Supply		81	65	65	66	57	51	42	33	81	45
Extract		80	63	66	68	60	54	45	34	78	47
Exhaust		78	65	70	71	62	59	53	45	80	50
Breakout		81	69	67	69	62	56	48	36	82	48
	Speed 80%	Lw dB - SOUND POWER OCTAVE BAND									Lp dB(A)
		63	125	250	500	1 K	2 K	4 K	8K	Tot	@3m
Intake		73	61	67	69	59	56	50	43	75	47
Supply		72	61	63	65	56	50	41	31	74	43
Extract		73	60	63	65	57	51	42	31	74	44
Exhaust		73	61	66	67	58	55	49	41	75	46
Breakout		71	64	62	67	59	53	45	33	74	45
	Speed 60%	Lw dB - SOUND POWER OCTAVE BAND									Lp dB(A)
		63	125	250	500	1 K	2 K	4 K	8K	Tot	@3m
Intake		65	61	68	67	58	56	49	41	72	46
Supply		63	59	63	64	55	49	40	29	69	42
Extract		64	59	63	63	56	51	41	30	69	42
Exhaust		64	60	66	67	57	54	48	41	71	45
Breakout		59	64	63	65	57	51	43	31	70	44
	Speed 40%	Lw dB - SOUND POWER OCTAVE BAND									Lp dB(A)
		63	125	250	500	1 K	2 K	4 K	8K	Tot	@3m
Intake		55	55	67	55	49	47	40	31	68	39
Supply		53	53	62	52	47	41	32	22	63	35
Extract		58	52	60	51	47	42	32	22	63	34
Exhaust		55	54	66	55	49	47	40	31	67	39
Breakout		54	53	59	52	48	43	33	23	62	34

Lp dB(A) @3m for comparative purposes only.