



# RONDO-150

## Bezrámový vetrací difúzor

Technická špecifikácia



reddot winner 2023

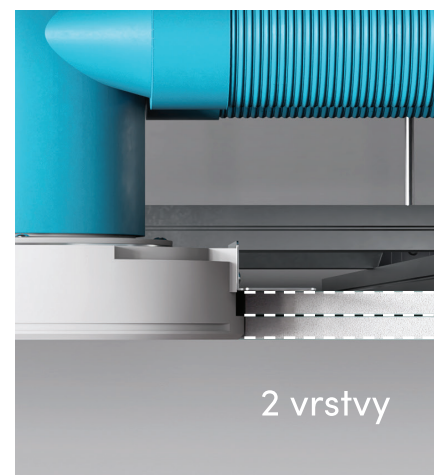
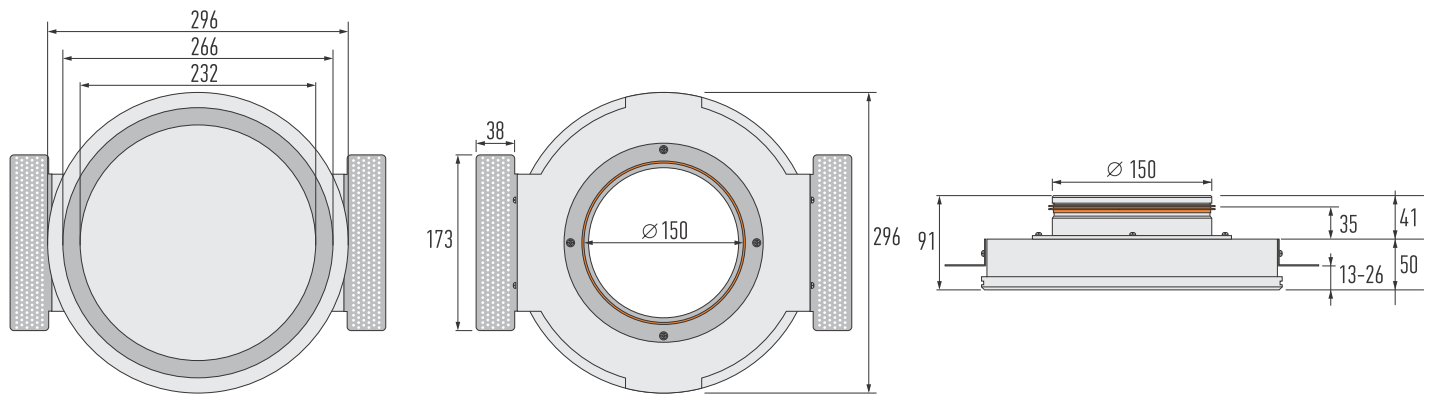

# RONDO-150

## Technické údaje

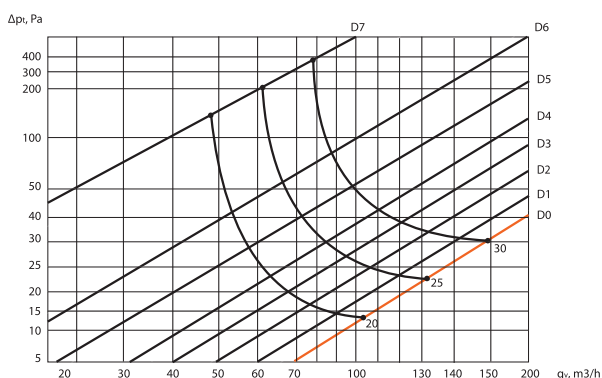
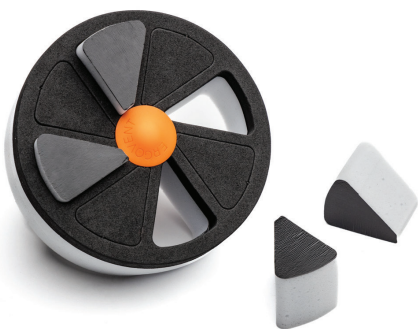
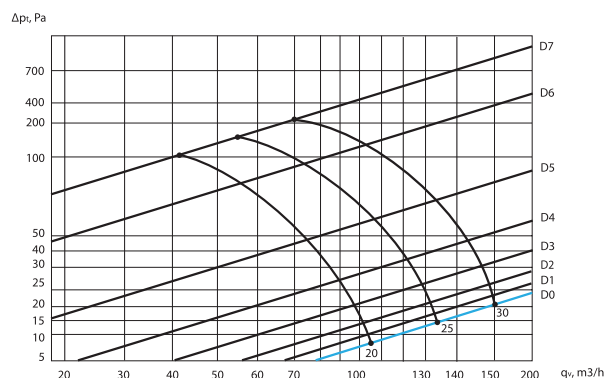
**RONDO 150 (prívod vzduchu)**

**RONDO 150 (odvod vzduchu)**

Na nastavenie prietoku vzduchu sa používa polyuretánová segmentová klapka

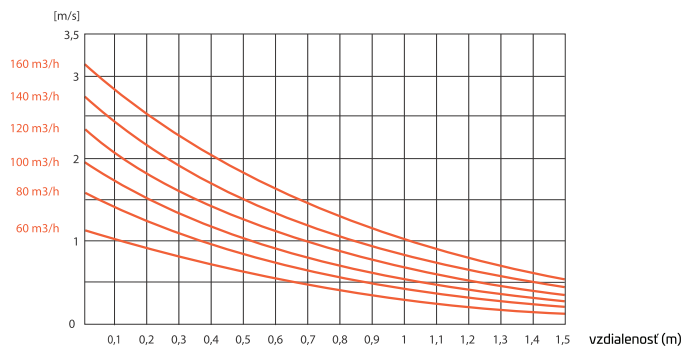
- D0 - bez vlozenej segmentovej klapky
- D1 - vložený 1 segment
- D2 - vložené 2 segmenty
- D3 - vložené 3 segmenty
- D4 - vložené 4 segmenty
- D5 - vložených 5 segmentov
- D6 - vložených 6 segmentov
- D7 - vložených 7 segmentov

**RONDO 150**  
rýchlosť, m/s

Naskenujte QR kód a stiahnite si návod na inštaláciu.